

Like
the hero?

*Love
the sidekick.*

Meet the Schaerer Coffee Skye: the ultimate sidekick for any niche where premium coffee and variety are a must. With its exceptional flexibility for smaller missions, it delivers outstanding coffee enjoyment exactly where it is needed. Inspired by the Schaerer Coffee Soul, it combines the same outstanding coffee competence with its own unique strengths: versatility and a smart pricing structure – perfect for less frequented locations.

The superpower of the Schaerer Soul, now in the Coffee Skye.

Ultimate indulgence.

Now unstoppable with Best Foam™.

Designed for mid-level demand locations, the Schaerer Coffee Skye delivers up to 180 cups per day with consistently high-end coffee quality and fits perfectly between the Schaerer Coffee Club and the Schaerer Coffee Soul 10/12. Each cup impresses with full-bodied flavour, aroma, and precision, ensuring that even in less frequented locations, there's no compromise on coffee enjoyment.

BEST FOAM™ – THE ULTIMATE MILK FOAM BOOST.

A perfect coffee experience isn't just about the beans. It's also about the perfect foam! For those who want to take their milk-based creations to the next level, Best Foam™ is available as an option, bringing barista-level milk foam at the touch of a button.*



* If you opt for Best Foam™, a mains water supply is required.

Great variety.
Fearless design.

The Schaerer Coffee Skye isn't just a coffee machine. It's a versatile powerhouse designed to meet a wide range of coffee preferences. With strong performance and customisable options, it ensures that every cup meets the highest standards of flavour and quality.

- **THE IDEAL ALL-ROUNDER:** high performance with flexible expansion options.
- **NTC SENSOR:** in combination with Pure Foam™, it ensures optimal foam quality at all times, regardless of the milk's incoming temperature.
- **TWIN MILK:** seamlessly adapts to different milk options, catering to diverse tastes and preferences.



Spectacular Selection. *Crafted for any niche.*

In addition to the great variety, the Schaerer Coffee Skye is designed for ultimate convenience, ensuring smooth installation, easy maintenance, and effortless expansion. With intelligent engineering, a smart design and user-friendly features, it adapts to any niche while maintaining top-tier performance.

- **HASSLE-FREE INSTALLATION:** front-facing hose guide for a simplified setup.
- **EFFORTLESS EXPANSION:** additional devices can be installed on either side without extra effort.
- **SMART DESIGN ELEMENTS:** integrated lighting and secure locking system for added convenience.
- **EASY MAINTENANCE:** all components are fully accessible from the front (main power, add-on devices, mains water supply, waste water drain), ensuring quick servicing. Hoppers are mounted externally above the machine and can be removed individually for easy cleaning.

Supreme Taste. *Teleported to where it is needed.*

With its integrated 4.9-liter water tank or connected to a fixed water supply, the Schaerer Coffee Skye delivers premium coffee quality wherever it's needed – without any limitations. Whether in boutique cafés, hotels, offices, or mobile setups, it ensures seamless operation in flexible environments.

- **MOBILE & ADAPTABLE:** The tank version is ideal for locations without a direct water connection.*
- **RELIABLE PERFORMANCE:** uncompromised coffee quality, wherever it's needed.

* Best Foam™ is excluded from this.



STANDARD FEATURES

- 8.0" touch screen display
- Single grinder with 750g bean hopper volume and manual inlet ("Decaf")
- Hot water on the left
- Functional illumination (left & right of the central outlet)
- Black housing and splash zone with red or black design elements
- Manual outlet with single/double coffee spout including relief chamber
- Internal water tank with closed and monitored drip tray

OPTIONAL FEATURES

- Pure Foam™ milk system
- Single/Twin powder (2000g/2x1000g) on the left
- Second grinder on the right
- Electrical adjustment per grinder
- Espresso blades per grinder
- Mains water supply with Uptime!
- Central hot water outlet
- Central hot water outlet, including additional water for Americano
- Powersteam or Supersteam on the right
- Brewing accelerator or additional water
- Side cooling unit left or right 1x7l
- Cooling unit 1x10l (Centre Milk, lateral or undercounter possible)
- 16g or 30g brewing unit
- 70 mm high feet
- Coming soon: Best Foam™ and bean hopper extension up to 1500g

TECHNICAL DETAILS

Weight: approx. 40kg

Recommended for an average daily requirement of: up to 180 cups

Measurements:

Width	330 mm
Depth	576 mm
Height	524 mm
Body incl. hoppers	680 mm
Body incl. keys	697 mm

Schaerer Coffee Skye

Front view - with side cooling unit 1x7l

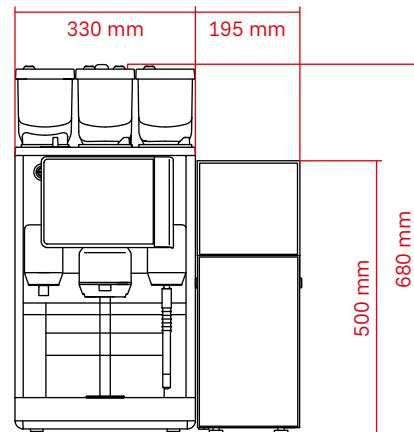

Side view left

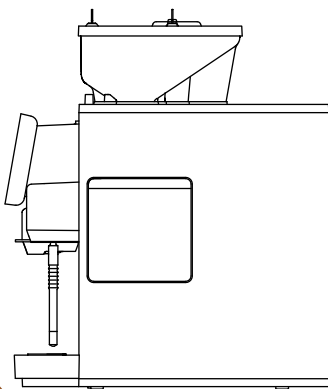

Front view

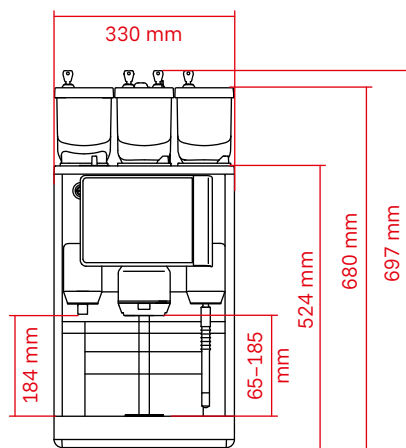

Side view right

