

MC18

The MC18 milk cooler is fitted with a nozzle for the drip tray drain and must be connected to a water drain on site using the hose supplied. Alternatively, the drain nozzle can be sealed with an end cap, mat. no. 26678.

The machine aperture in the table top can also be used to insert the connection hoses and connection cables if necessary.

Dimensions:	W/D/H approx. 180 x 580 x 580 mm
Connection data:	200 - 240 V / 50 - 60 Hz
Power consumption:	approx. 150 W
Milk container volume:	approx. 5 l
Installation weight when filled:	approx. 22 kg

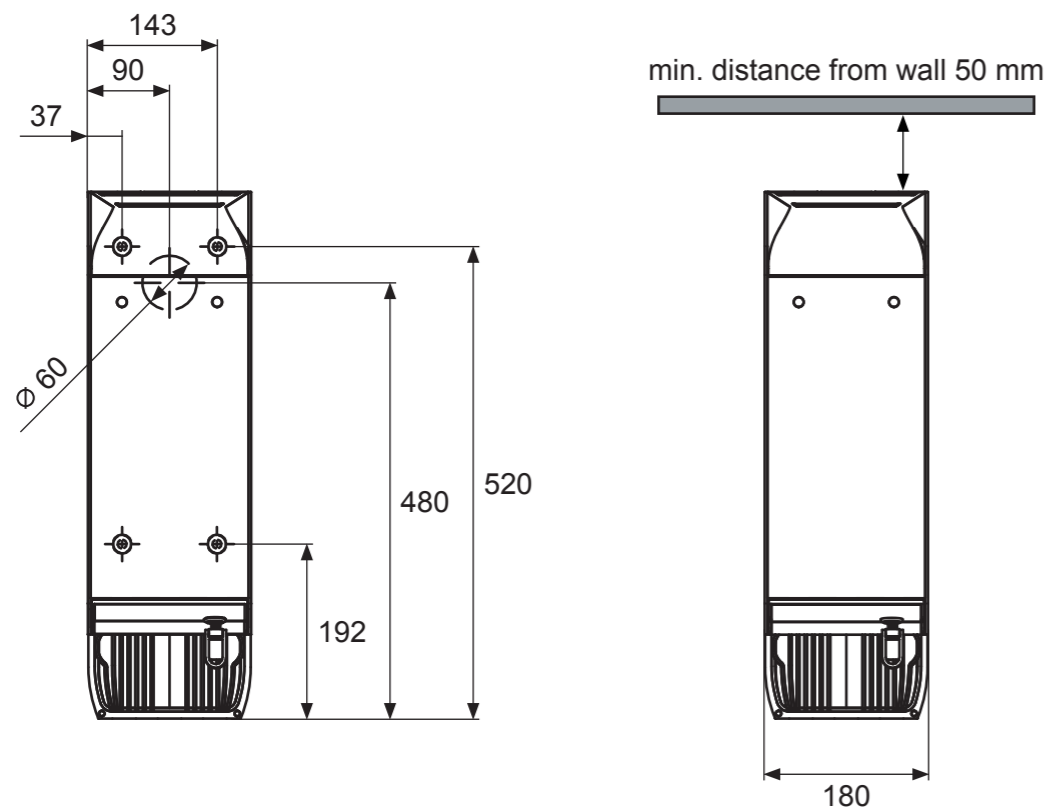

All dimensions are approximate dimensions in millimeters.

Date: 08/2017
Page: 1/6

Subject to changes.
Property of Melitta.
Reproduction prohibited.



Melitta® Cafina® XT Series
Accessory Units
MC18
Dimension and datasheet

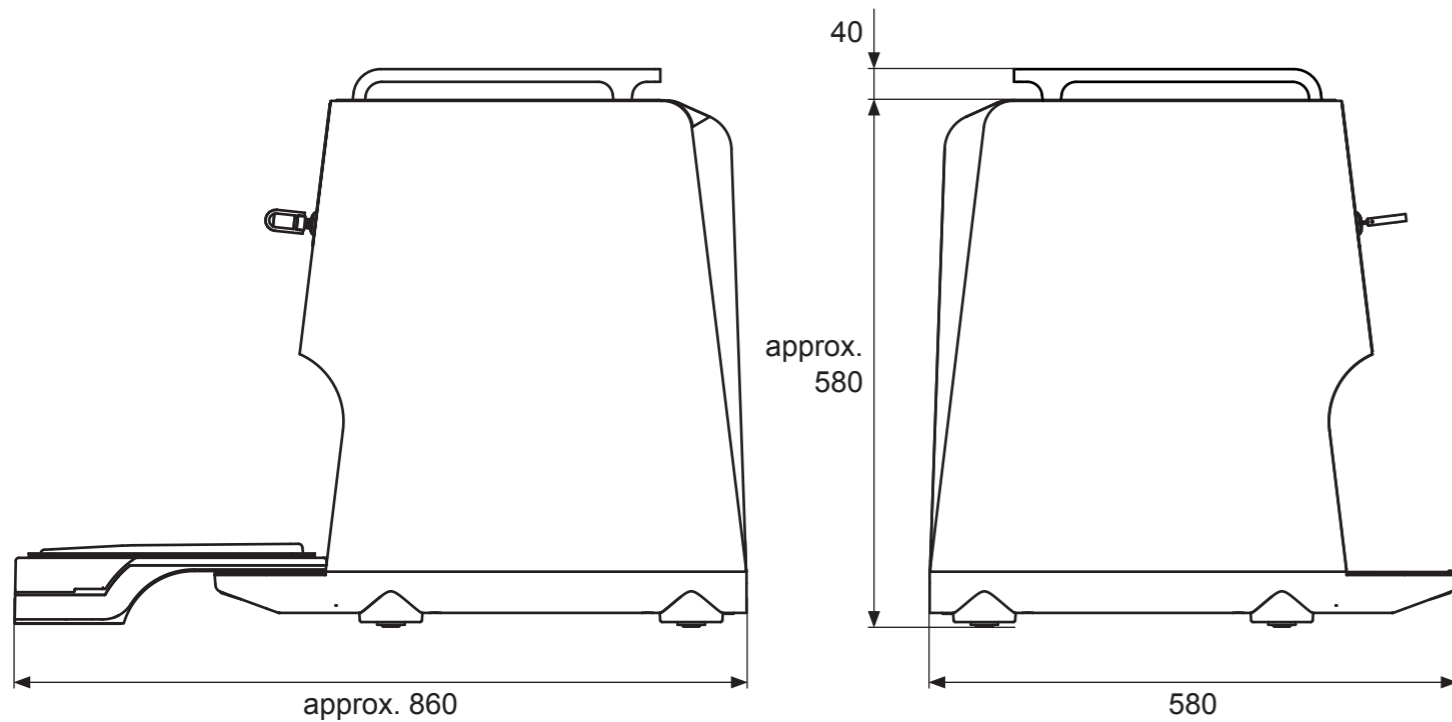

MC30

For one or two types of milk.

The MC30 milk cooler is fitted with a nozzle for the drip tray drain and must be connected to a water drain on site using the hose supplied. Alternatively, the drain nozzle can be sealed with an end cap, mat. no. 26678.

The machine aperture in the table top can also be used to insert the connection hoses and connection cables if necessary.

Dimensions:	W/D/H approx. 300 x 580 x 620 mm
Connection data:	200 - 240 V / 50 - 60 Hz
Power consumption:	approx. 150 W
Milk container volume:	2 x approx. 5 l
Installation weight when filled:	approx. 34 kg

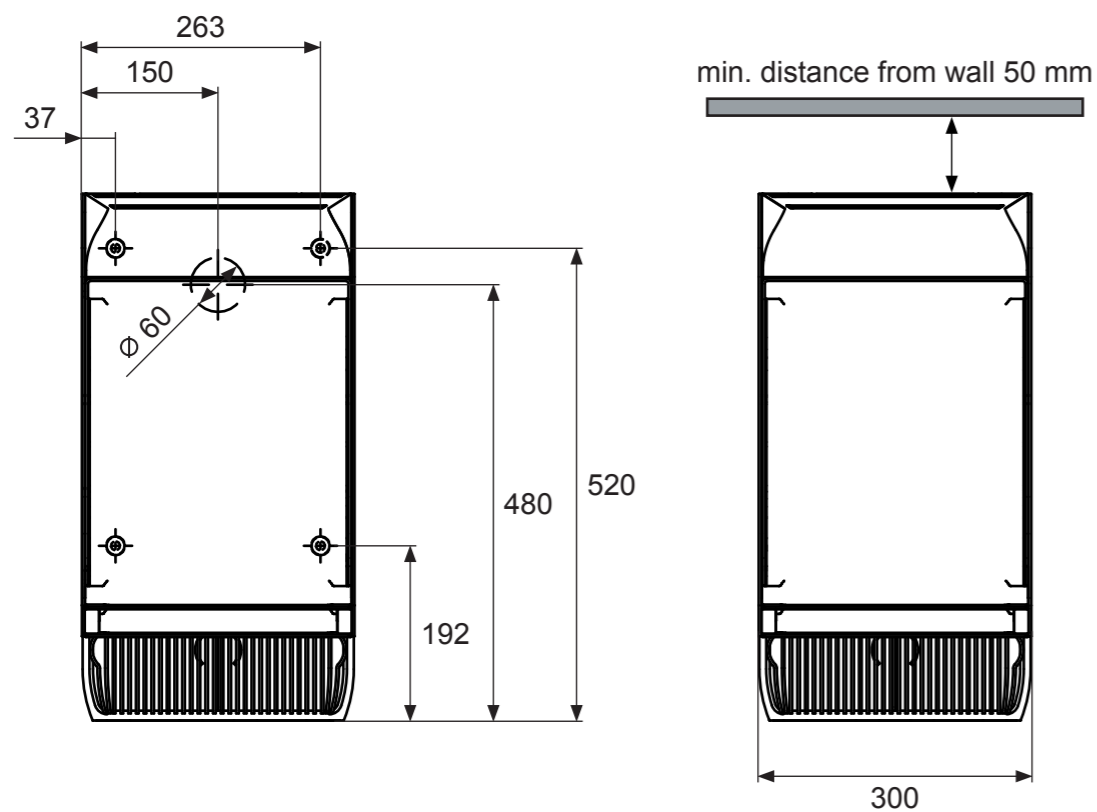

All dimensions are approximate dimensions in millimeters.

Date: 08/2017
Page: 2/6

Subject to changes.
Property of Melitta.
Reproduction prohibited.



Melitta® Cafina® XT Series
Accessory Units
MC30

Dimension and datasheet

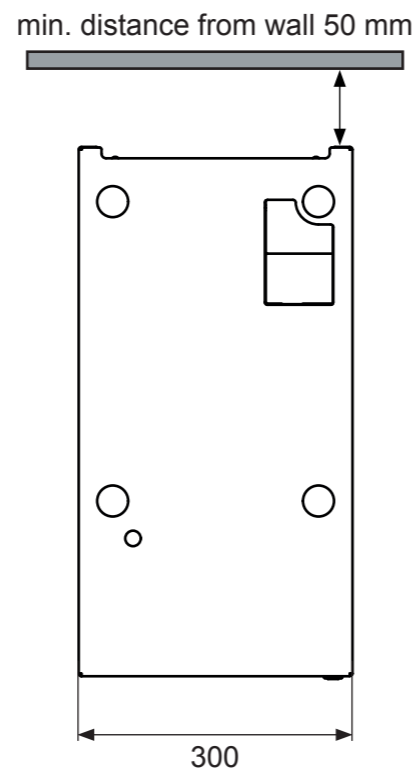
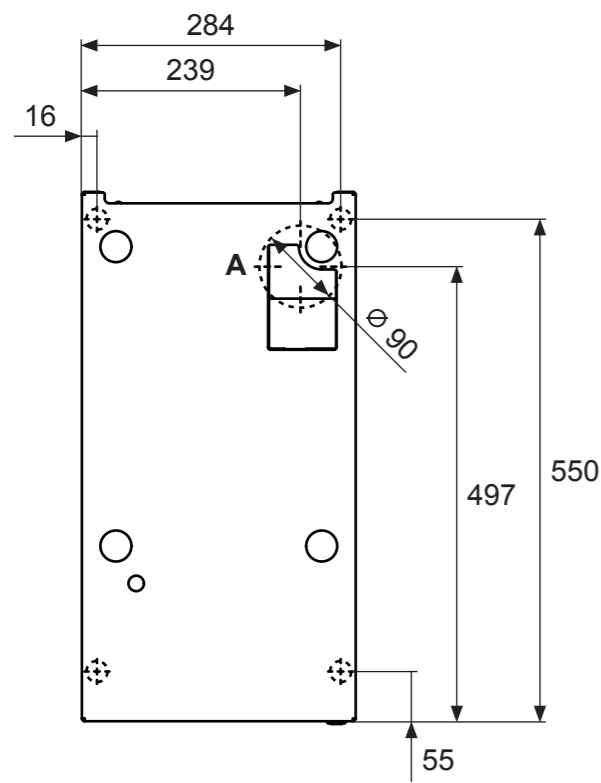
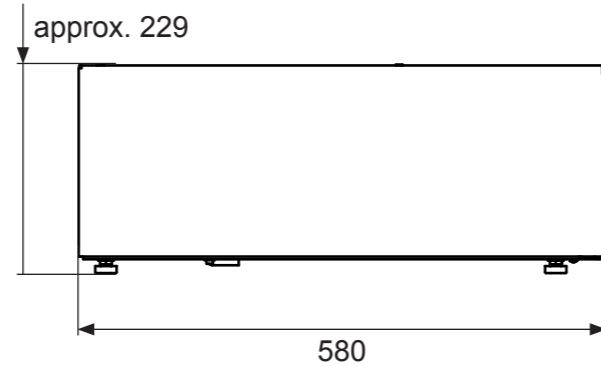
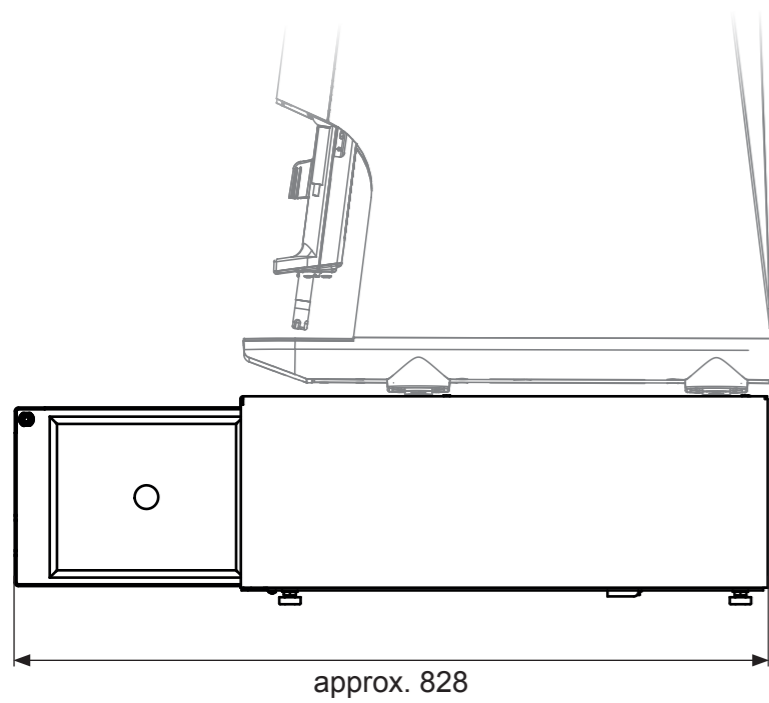

MCU30

The MCU30 milk cooler is a base unit. The machine is placed on the milk cooler in the designated recesses.

This unit cannot be used for machines with container ejection.

To insert the connection hoses and the connection cables, an aperture (A) is required in the table top underneath the unit measuring approx. 90 mm.

Dimensions:	W/D/H approx. 300 x 580 x 229 mm
Connection data:	200 - 240 V / 50 - 60 Hz
Power consumption:	approx. 150 W
Milk container volume:	approx. 4 l
Installation weight when filled:	approx. 25 kg

Date: 08/2017
Page: 3/6

Subject to changes.
Property of Melitta.
Reproduction prohibited.



Melitta® Cafina® XT Series
Accessory Units
MCU30
Dimension and datasheet

All dimensions are approximate dimensions in millimeters.

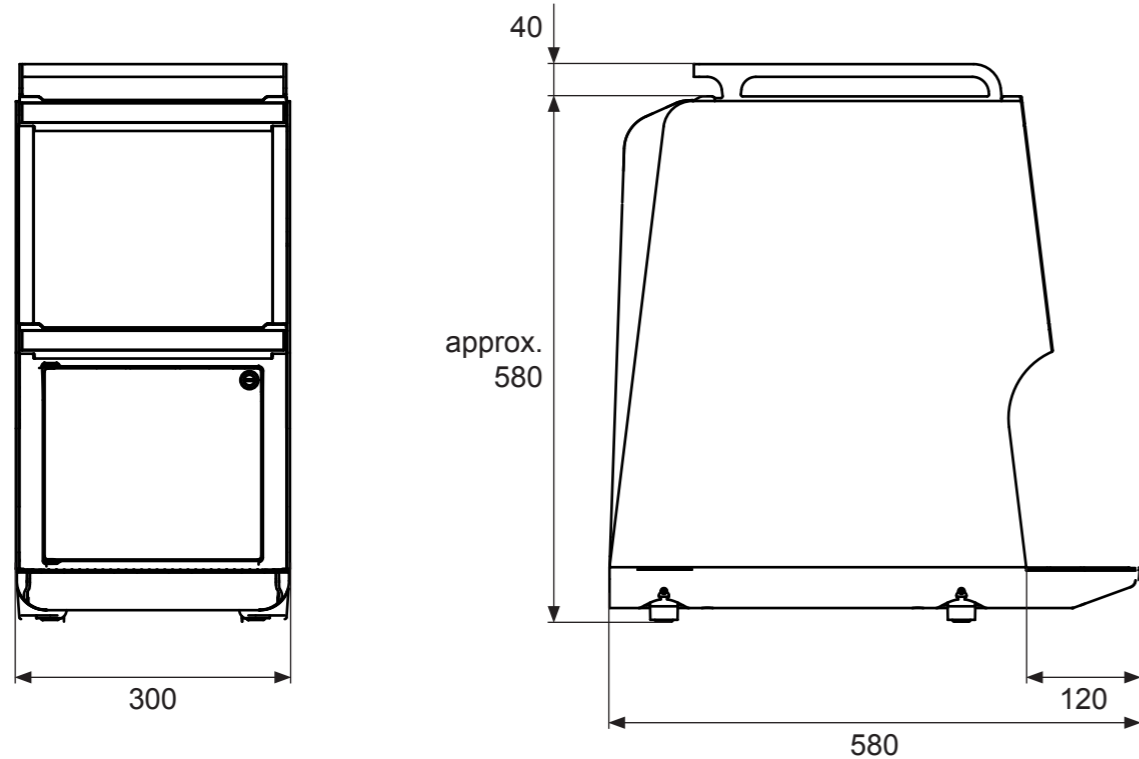

MC-CW30

The MC-CW30 is fitted with a nozzle for the drip tray drain and must be connected to a water drain on site using the hose supplied. Alternatively, the drain nozzle can be sealed with an end cap, mat. no. 26678.

The machine aperture in the table top can also be used to insert the connection hoses and connection cables if necessary.

Dimensions: W/D/H approx. 300 x 580 x 620 mm

Connection data: 200 - 240 V / 50 - 60 Hz

Power consumption: approx. 165 - 230 W

Operating temperature of functional surfaces: up to 75 °C

Capacity: approx. 40 - 80 cups

Milk container volume: approx. 4 l

Installation weight filled & incl. cups: approx. 42 kg

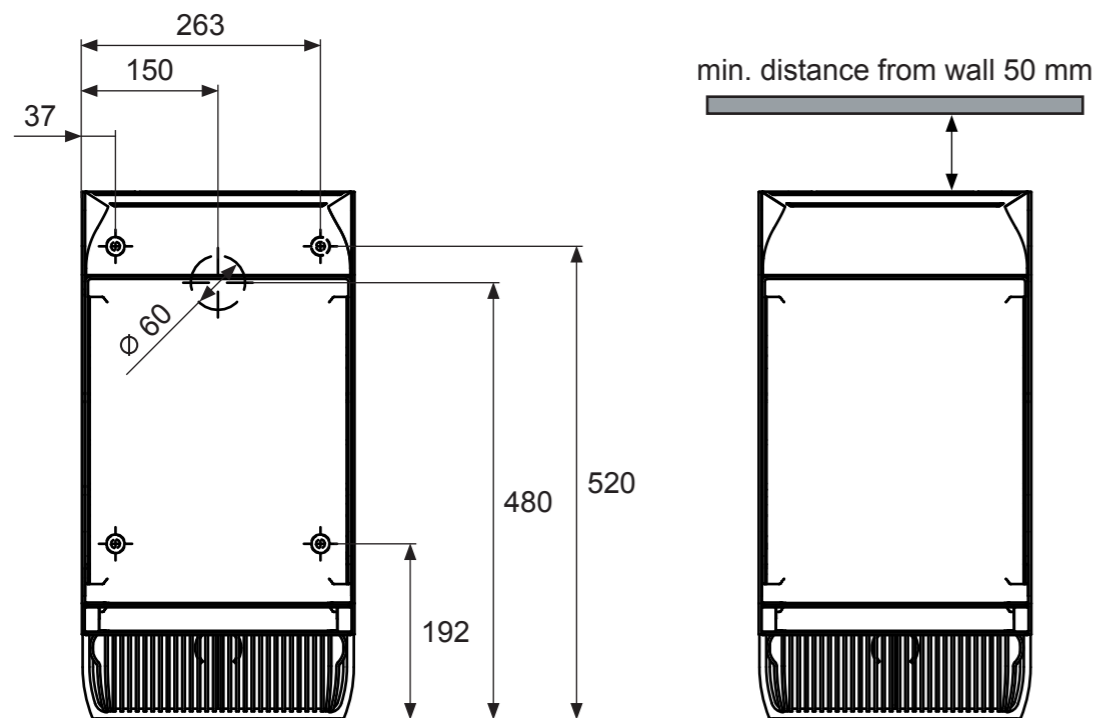

All dimensions are approximate dimensions in millimeters.

Date: 08/2017
Page: 4/6

Subject to changes.
Property of Melitta.
Reproduction prohibited.



Melitta® Cafina® XT Series
Accessory Units
MC-CW30

Dimension and datasheet

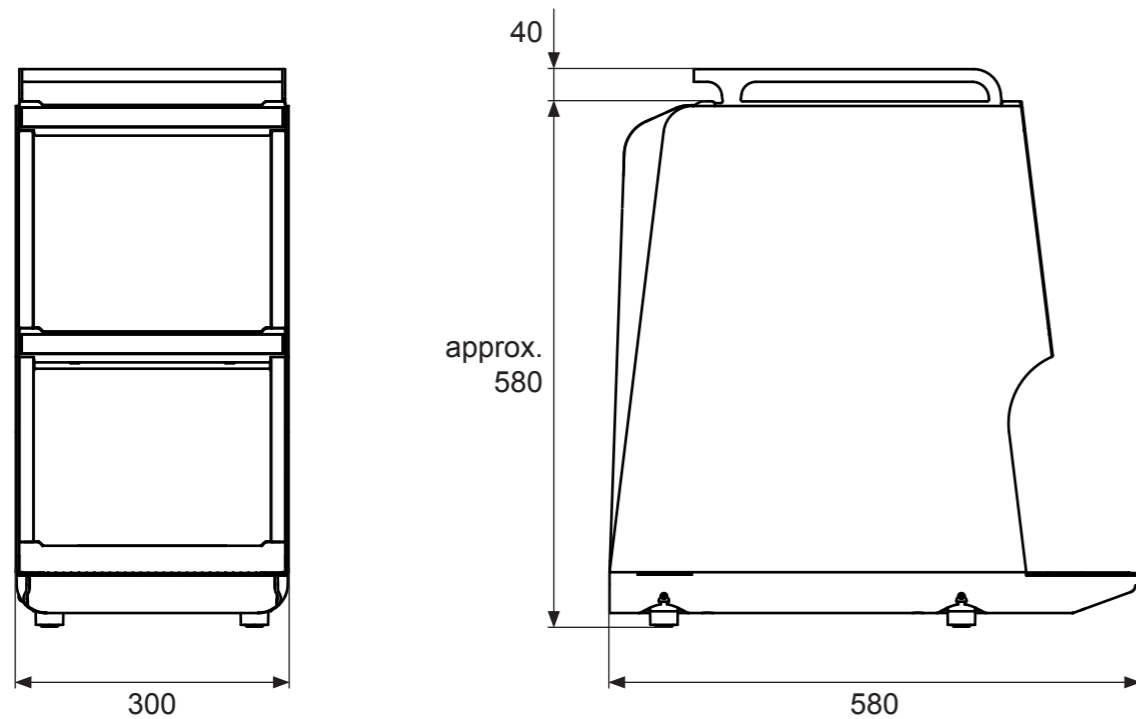

CW30

The CW30 cup warmer is fitted with a nozzle for the drip tray drain and must be connected to a water drain on site using the hose supplied. Alternatively, the drain nozzle can be sealed with an end cap, mat. no. 26678.

The machine aperture in the table top can also be used to insert the connection hoses and connection cables if necessary.

Dimensions: W/D/H approx. 300 x 580 x 620 mm

Connection data: 200 - 240 V / 50 - 60 Hz

Power consumption: approx. 210 - 300 W

Operating temperature of functional surfaces: up to 75 °C

Capacity: approx. 80 - 120 cups

Installation weight incl. cups: approx. 41 kg

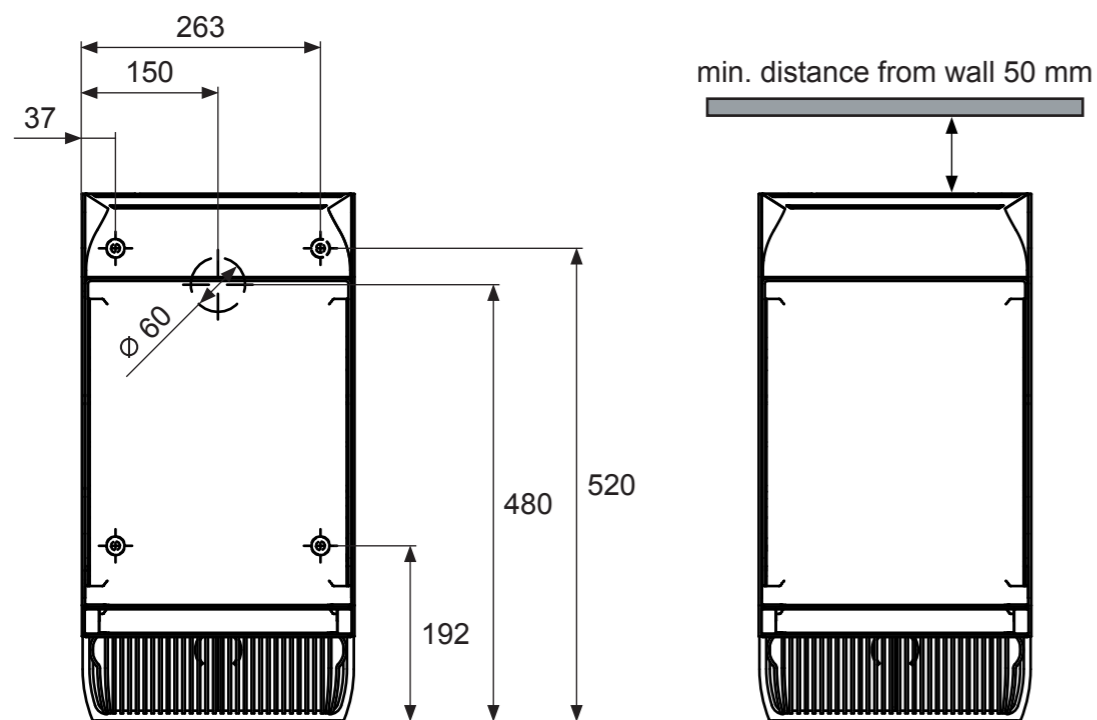

Date: 08/2017
Page: 5/6

Subject to changes.
Property of Melitta.
Reproduction prohibited.



Melitta® Cafina® XT Series
Accessory Units
CW30

Dimension and datasheet

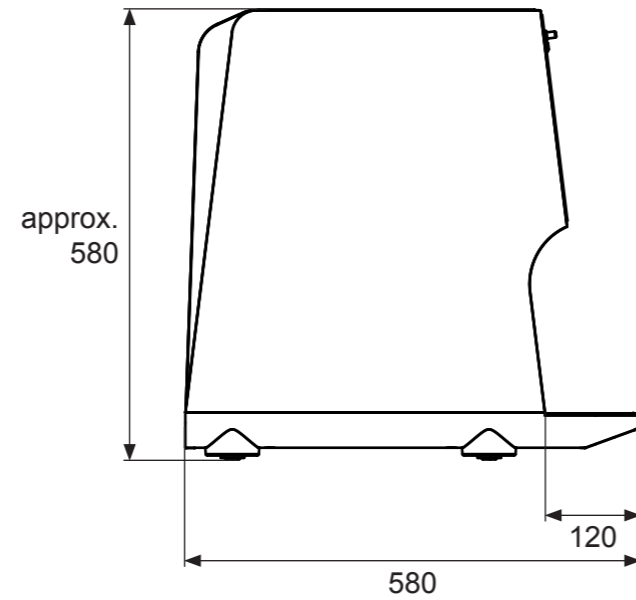
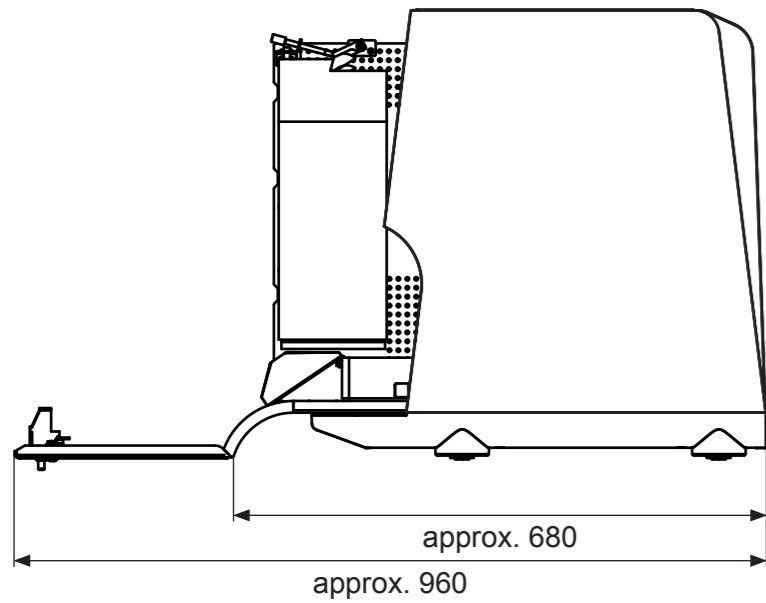

Accounting systems

The following units serve as accounting systems:

- Melitta Cafina XT CA – Coin acceptor
- Melitta Cafina XT CC – Coin changer
- Melitta Cafina XT CR – Card reader

The accounting systems are generally supplied with power via the coffee machine.

The front flap must be able to open fully in order to operate and service the units. The front flap needs extra space in front in order to open downward fully (depending on the screw height of the feet).

Dimensions: W/D/H approx. 180 x 580 x 580 mm

Installation weight: approx. 10 kg

The figures show the XT CC unit. The dimensions and data are the same for all accounting systems.

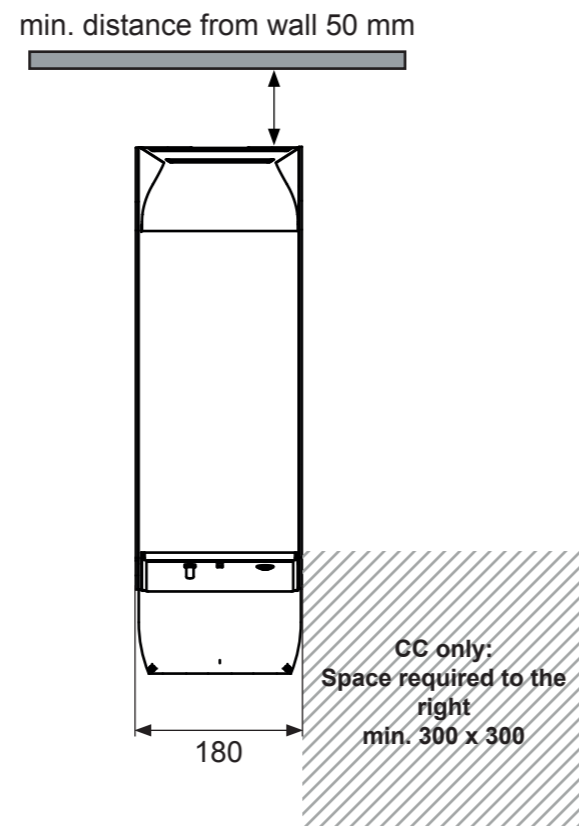
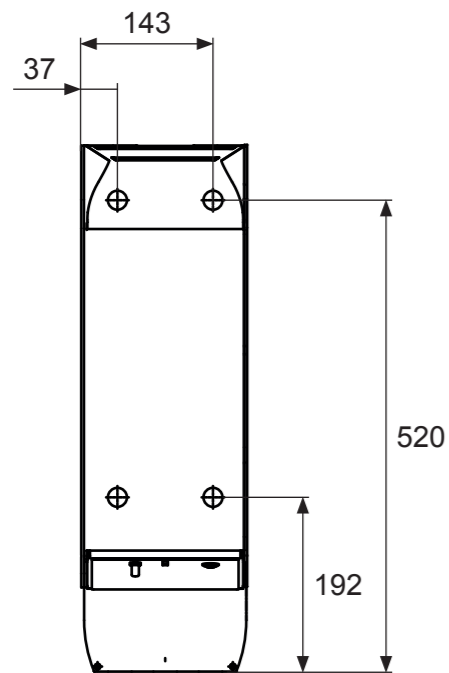

All dimensions are approximate dimensions in millimeters.

Date: 08/2017
Page: 6/6

Subject to changes.
Property of Melitta.
Reproduction prohibited.



Melitta® Cafina® XT Series
Accessory Units
Accounting systems
Dimension and datasheet